

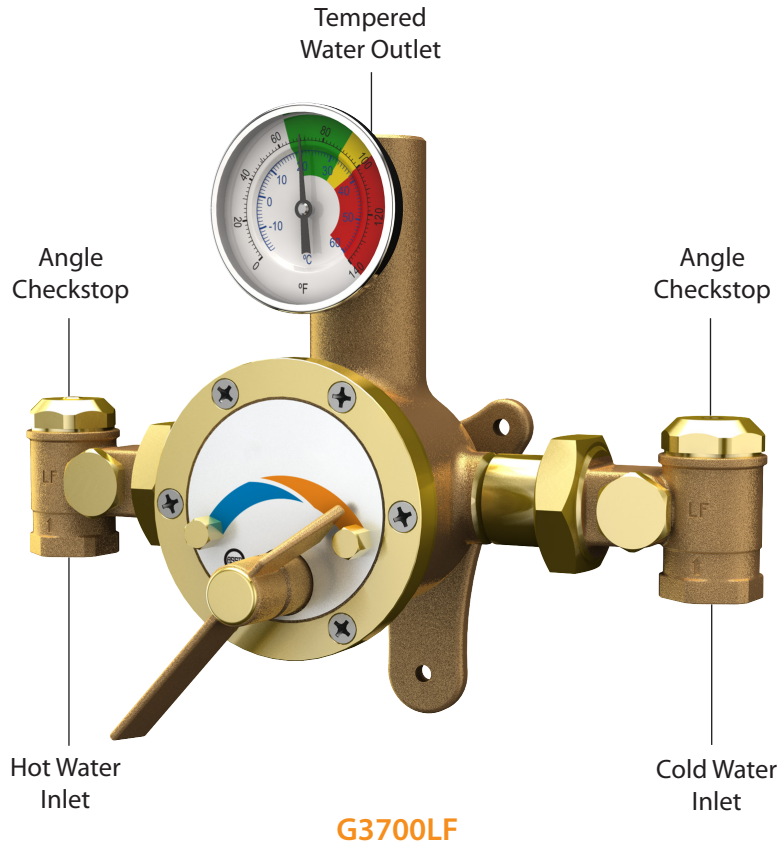

Note: Please provide valve serial number (stamped on cover of valve) when ordering parts.



Installation

1. Install valve in a location where it may be easily cleaned, adjusted or repaired.
2. Inlets are clearly marked on valve body casting. Connect hot water to inlet marked "HOT" and cold water to inlet marked "COLD."
3. Included angle checkstops must be installed on both supply lines.
4. Use solder or pipe cement sparingly. Flush supply pipes before connecting valve. Flush outlet pipe and valve once valve is connected.

Maximum operating pressure is 125 PSI (860 KPA) for hot and cold water. Maximum hot to cold water pressure differential is 5%.

Note: Should piping be exposed to excessive hot or cold conditions, it may be necessary to insulate piping to prevent freezing or scalding water.



IMPORTANT: THESE SYSTEMS ARE DESIGNED TO PROVIDE MIXED WATER FROM 60 TO 90°F (15 TO 32°C) FOR EMERGENCY EQUIPMENT APPLICATIONS ONLY IN ACCORDANCE WITH ASSE 1071.

Note: This is a control system which must be cleaned and maintained regularly (see Maintenance Guide and Record card included with valve shipment).

Adjustment and Service

Guardian thermostatic mixing valves may be easily cleaned, adjusted and repaired. Servicing may be possible without disconnecting valve.

Note: Thermostatic water mixing valves are regulating mechanisms which must be regularly maintained to provide best performance. Local water quality and usage conditions dictate cleaning frequency. (See Maintenance Guide and Record card included with valve shipment and reference ANSI Z358.1)

To Reset Adjustable High Temperature Limit Stop:

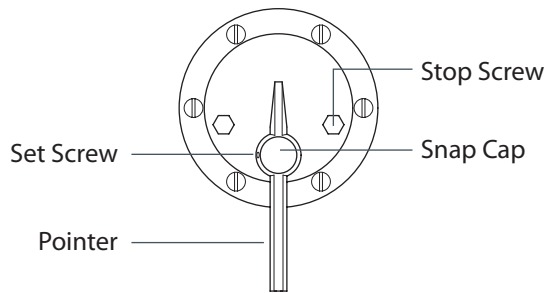

1. Loosen set screw. Remove snap cap, pointer screw, washer, and pointer.
2. Activate emergency fixture.
3. Temporarily place pointer on pointer rod and turn handle to the left, allowing cold water to flow. Then, slowly adjust handle to the right until the required maximum temperature is reached. *Note: Temperatures above 90°F are not recommended. Consult a medical advisor for correct temperature settings.*
4. Once maximum temperature has been reached, remove pointer and replace on pointer rod such that its right edge rests against the stop screw located on the right side of the cover.
5. Tighten set screw and replace washer, pointer screw, and snap cap. Hold a thermometer under water flow to verify maximum temperature has been set appropriately. Then set desired operating temperature.



WARNING: THIS THERMOSTATIC MIXING VALVE HAS AN ADJUSTABLE HIGH TEMPERATURE LIMIT STOP WHICH MUST BE CHECKED. IF TEMPERATURE IS TOO HIGH, THE INSTALLER MUST RESET THIS STOP IMMEDIATELY. ALWAYS CHECK THE TEMPERATURE OF THE MIXED WATER WHEN THE LEVEL HANDLE IS TURNED TO FULL HOT. THE WATER TEMPERATURE OF EACH INDEPENDENT OUTPUT MUST BE CHECKED IF USING A COMBINATION UNIT. EXCESSIVE HOT WATER TEMPERATURE IS DANGEROUS AND MAY CAUSE SCALDING.

THE HIGH TEMPERATURE LIMIT STOP IS FACTORY SET AT APPROXIMATELY 90°F (32°C) WITH AN INCOMING HOT WATER SUPPLY TEMPERATURE OF 135°F (57°C). IF THE INCOMING HOT WATER IS HIGHER THAN 135°F (57°C), THE VALVE (WHEN TURNED TO FULL HOT) WILL DELIVER WATER IN EXCESS OF 90°F (32°C) AND THE HIGH TEMPERATURE LIMIT STOP MUST BE RESET.

Troubleshooting

Symptom	Component Type	Part No.	Description
Leak at pointer rod.	Packings and Gaskets	MU-5A	O-Ring
Leak between valve cover and body.	Packings and Gaskets	TM-21/50	Flange Packing
Valve outlet temperature will not mix consistently.	Port Sleeve Assembly	TGM-1/50M or RK3800A	Port Sleeve Assembly or Repair Kit
After cleaning or replacing port sleeve assembly, valve will not hold temperature.	Thermostat Group	TGM-2/50 or RK3800A	Thermostat Group or Repair Kit
Hot water bypass into cold line.	Checkstops	RK3800B	Checkstop Kit
Supplies cannot be shut off completely.	Checkstops		
Leak at checkstop bonnet.	Checkstops		

If installed on a circulated hot water system, verify the valve is piped according to Required Piping Method on page 3.

See page 5 for complete parts breakdown and parts kits.

Note: This is a control system which must be cleaned and maintained regularly (see Maintenance Guide and Record card included with valve shipment).



Required Piping Method

Required when hot water must be circulated to a thermostatic mixing valve that is a substantial distance from the hot water source. Recommended hot water inlet temperature is 135°F (57°C).

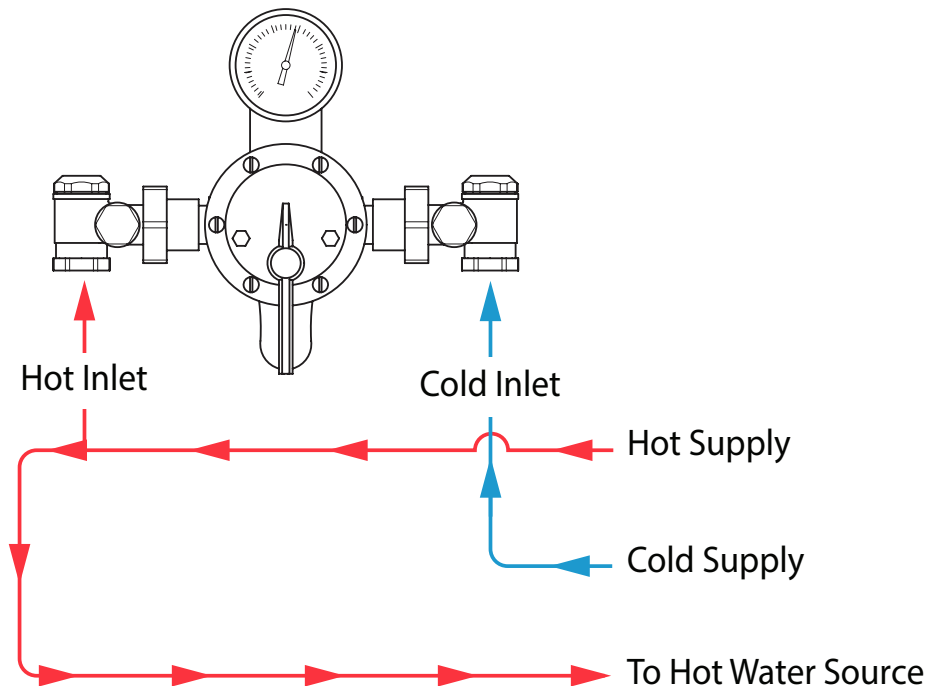

G3700LF

This unit must be cycled each time the emergency equipment is inspected (See ANSI Z358.1, Maintenance and Training Section).

1. Set the thermostatic mixing valve to full hot.
2. Activate emergency equipment and allow temperature to reach set point.
3. Turn thermostatic mixing valve to full cold and wait ten seconds.
4. Turn thermostatic mixing valve to full hot and wait ten seconds.
5. Verify outlet temperature does not exceed 90°F (32°C).
6. Turn thermostatic mixing valve to full cold and wait ten seconds.
7. If necessary, adjust high temperature limit stop (see page 2). Then set mixing valve to desired operating temperature and deactivate emergency equipment.

Note: This is a control system which must be cleaned and maintained regularly (see Maintenance Guide and Record card included with valve shipment).

To Dismantle Valve:

Shut off hot and cold water supplies to valve. Loosen set screw. Remove snap cap, pointer screw, washer, pointer and friction spring (see Figure 1). Remove cover screws and cover (thermostat and gears are attached to cover).

When reassembling, insert flange packing into valve body and replace cover and cover screws. Then replace friction spring, pointer, washer, screw, and snap cap.

After replacing parts, pointer must be reset. Refer to page 2 instructions "To Reset Adjustable High Temperature Stop."

To Clean Port Sleeve Assembly:

Screw (twist) the check nut away from valve body towards port sleeve assembly. Then twist port sleeve nut away from port sleeve assembly (towards valve body) to release port sleeve and thimble (Figure 2).

Clean with non-corrosive agent and soft cloth. **DO NOT USE ABRASIVES.** Wash parts thoroughly after cleaning and reassemble.

Install port sleeve with elongated holes nearest the check nut and tighten port sleeve nut against port sleeve assembly. **DO NOT OVERTIGHTEN.** Tighten check nut against valve body. Driving ball on thermostat group should then be inserted into ball socket for final reassembly (Figure 1).

To Replace Pointer Rod With Gear:

Loosen set screw and remove snap cap, pointer screw, washer, pointer and friction spring (Figure 1). Remove cover screws and cover. Then remove coil sleeve stud and thermostat group. Replace pointer rod with gear, and reassemble.

To Replace or Clean Thermostat Group:

See "To Replace Pointer Rod with Gear" (above) to disassemble valve. Clean any collected deposits from thermostatic coil with brush and non-corrosive cleaning solution.

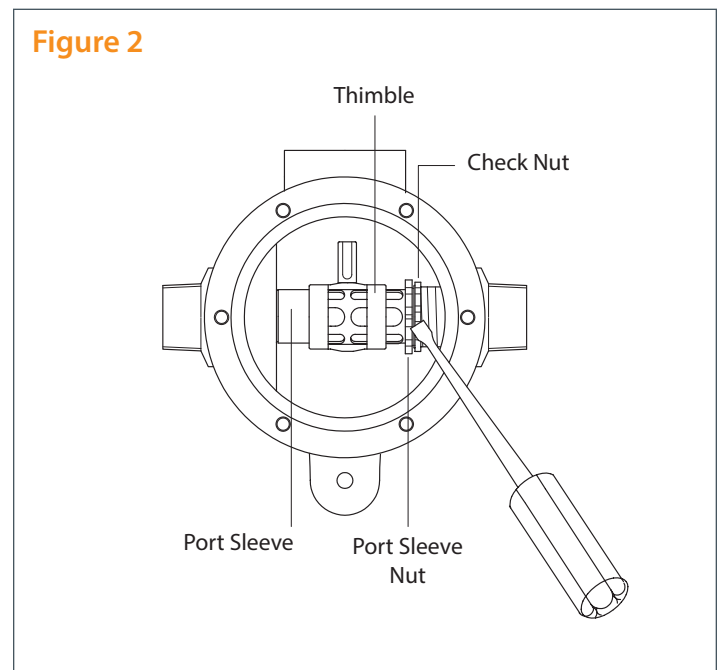
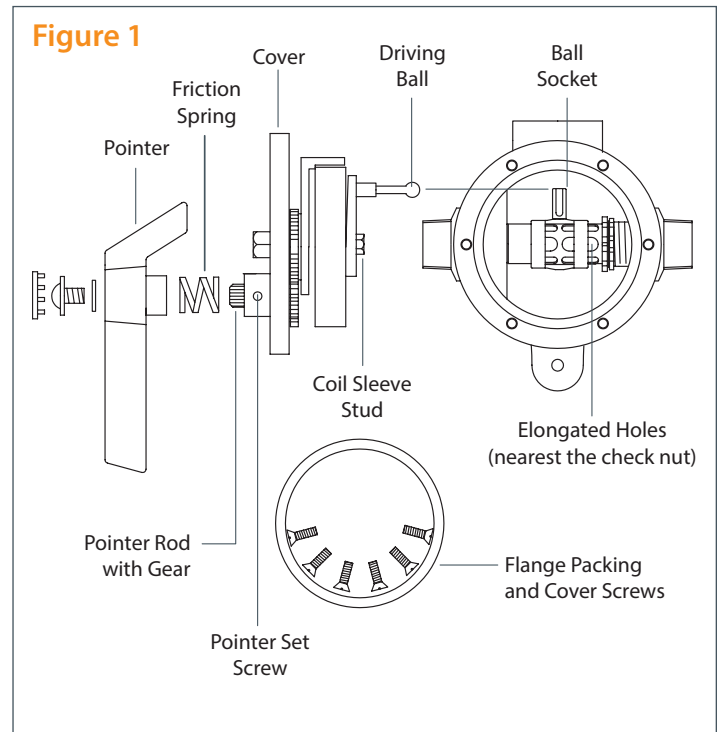

Note: This is a control system which must be cleaned and maintained regularly (see Maintenance Guide and Record card included with valve shipment).



Thermostatic Mixing Valve Parts

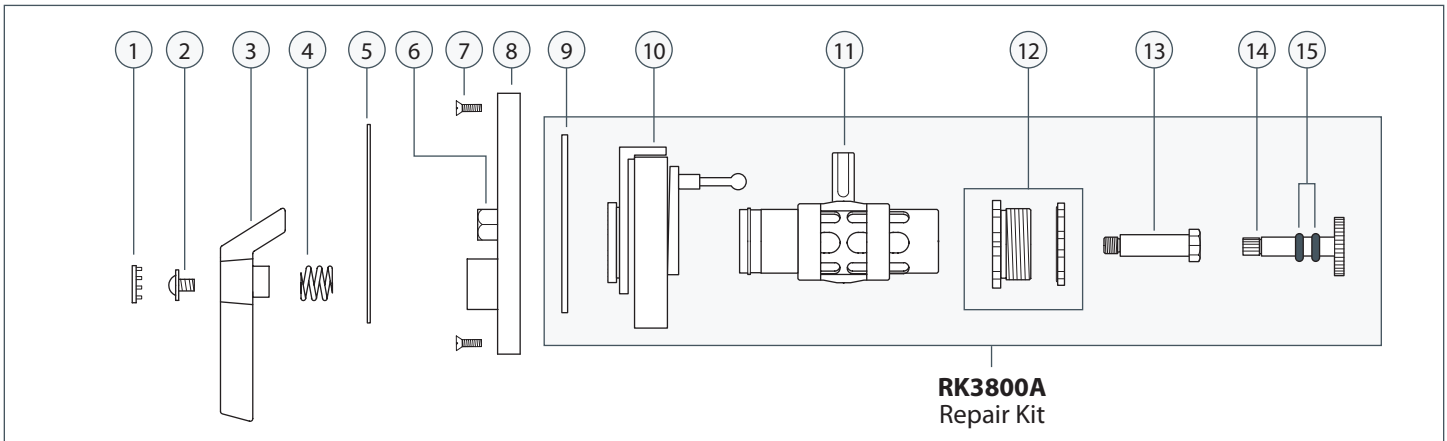

Checkstop Parts

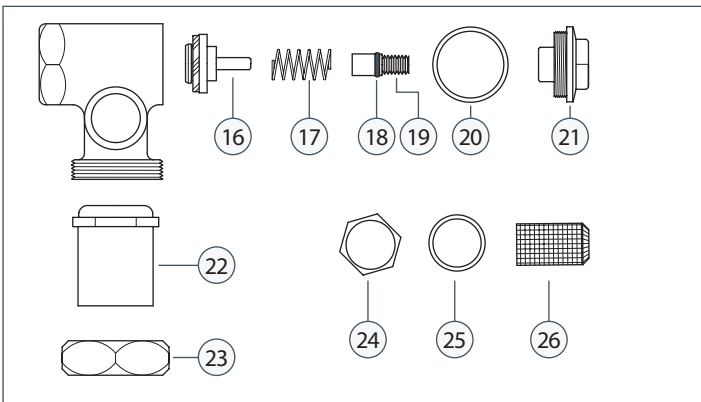

Repair Kits

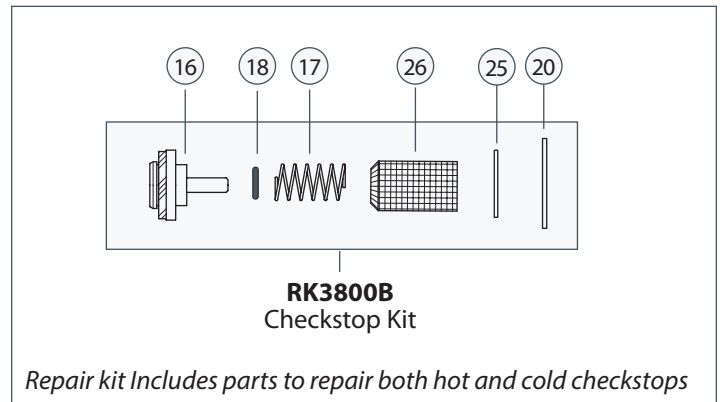

Lockable Pointer (suffix "LTR")

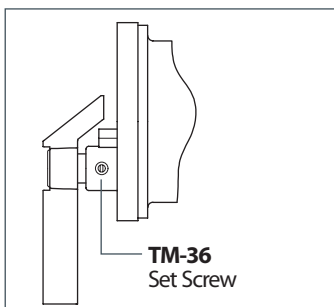

Notes:

1. After installing new parts, the adjustable high temperature limit stop must be reset (see page 2).
2. All G3700LF valves are furnished with a lockable pointer.

Item	Part No.	Description
1	57-L	Snap Cap
2	TM-29/29A	Pointer Screw
3	TM-25C	Pointer
4	30	Friction Spring
5	615	Dial Plate
6	TM-25D	Stop Screw
7	TM-16	Cover Screws (6)
8	TM-15B/50	Cover
9	TM-21/50	Flange Packing
10	TGM-2/50	Thermostat Group
11	TGM-1/50M	Port Sleeve Assembly
12	TM-3/50M	Port Sleeve Nut Assembly
13	TM-8	Coil Sleeve Stud
14	TM-28A	Pointer Rod

Item	Part No.	Description
15	MU-5A	O-Ring
16	03	Lower Stem & Packing
17	011	Spring (Hot Side)
	015	Spring (Cold Side)
18	MU-5A	O-Ring
19	MU-4A	Upper Stem
20	05	Packing
21	02	Bonnet
22	04/50	Swivel
23	09/50	Swivel Nut
24	06	Strainer Cap
25	014	Cap Packing
26	013	Screen

Note: This is a control system which must be cleaned and maintained regularly (see Maintenance Guide and Record card included with valve shipment).



Flow Capacities

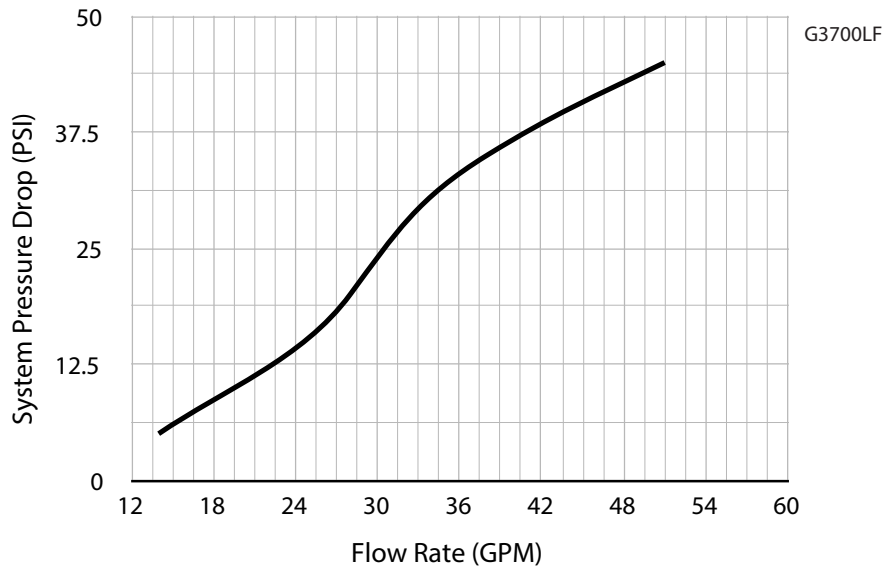

MODEL	IN	OUT	MINIMUM FLOW (GPM) L/MIN	INTERNAL COLD WATER BYPASS MINIMUM	SYSTEM PRESSURE DROP									
					5	10	15	20	25	30	35	40	45	PSI
G3700LF	3/4"	1"	3	20	14	19	25	28	30	33	38	44	51	GPM
			11	76	53	72	95	106	114	125	144	167	193	L/MIN
MAXIMUM FLOW CAPACITY														



CAUTION: ALL THERMOSTATIC MIXING VALVES HAVE LIMITATIONS. THEY WILL NOT PROVIDE THE DESIRED ACCURACY OUTSIDE OF THEIR FLOW CAPACITY RANGE. CONSULT THE CAPACITY CHART AND DO NOT OVERSIZE. MINIMUM FLOW MUST BE NO LESS THAN SHOWN ABOVE.



IMPORTANT: THESE SYSTEMS ARE DESIGNED TO PROVIDE MIXED WATER FROM 60 TO 90°F (15 TO 32°C) FOR EMERGENCY EQUIPMENT APPLICATIONS ONLY IN ACCORDANCE WITH ASSE 1071.

Limited Warranty

Guardian Equipment warrants the original purchaser that its products will be free from defects in materials and workmanship under normal usage conditions, and when properly installed and maintained according to manufacturer's instructions for a period of two years from date of shipment. During the warranty period, Guardian Equipment will (at its discretion) repair or replace any product or part thereof, which shall be returned, freight prepaid to Guardian's factory and determined by the manufacturer to be defective in materials or workmanship. There are no warranties, expressed or implied, which extend beyond verbiage contained herein. There are no implied warranties of merchantability or fitness for a particular purpose. Guardian Equipment will not be held liable for labor, incidental or consequential damages. Any alteration or improper installation or improper use of the product will void this limited warranty.

Note: This is a control system which must be cleaned and maintained regularly (see Maintenance Guide and Record card included with valve shipment).